

PIM-120 Protectowire Single Zone Mini-Interface Module

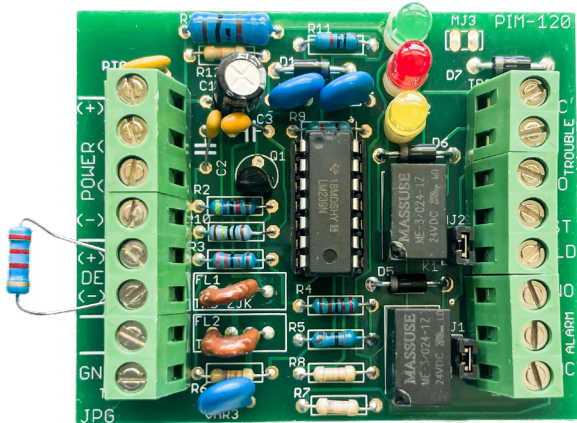

General

The PIM-120 is a single zone detection module that interfaces between a main control panel detection circuit or addressable node and Protectowire Linear Heat Detector. The module provides a Class B (Style B) initiation circuit capable of operating up to 2,000 m (6,560 ft.) of Protectowire as well as other types of normally open non-resistive contact devices.

Description

The PIM-120 Protectowire Interface Module is designed for easy mounting using a convenient “snap-lock” mounting track that enables the module to be installed inside a host control panel or in any enclosure meeting the application requirements.

In order to ensure proper operation, each PIM-120 Interface Module requires regulated 24 VDC external power which is normally provided by the host control panel. A Green “Power On” LED indicator is provided on each PIM-120 to provide a visual confirmation that the module is powered.

One set of Form C alarm contacts and one set of Form C trouble contacts are provided on each module and are

Features

- Monitors up to 2,000m (6,560 ft.) of Protectowire Linear Heat Detector.
- Individual alarm, trouble, and power on LED's.
- Versatile track mounting.
- Easily mounts in standard electrical boxes.

used to connect the unit to a corresponding detection zone in the host fire alarm panel. The module's alarm circuit is non-latching and self restores upon clearing the initiating circuit alarm state. The host panel's zone detection circuit is used to retain the system's alarm latch (memory) until manually reset.

Each PIM-120 Interface Module can be configured with a shunt diode barrier to provide an intrinsically safe Class B detection circuit for those areas that are classified as hazardous. In this configuration the maximum length of Protectowire that can be connected to the circuit is 1,829m (6,000 ft.), however additional limitations may apply depending upon the specific requirements of the hazardous application. The shunt diode barrier limits the voltage and current in the detection circuit to values that are incapable of causing an explosion in areas that are classified as Class I, II, or III, Division 1, Groups A, B, C, D, E, F, & G. Only Protectowire Linear Heat Detector and/or a non-energy storing contact initiating device may be used on PIM-120 intrinsically safe detection circuits. The intrinsic safety barrier compatible for use with the PIM-120 is part number 9001/01-280-100-101 as manufactured by R. Stahl Inc. Consult the Factory for specific information on hazardous location installations.

Specifications

Electrical

- Regulated 24 VDC (+10% / -15%) @ 20 mA standby, 40 mA alarm.
- Power limited, onboard surge and EMI protection devices.
- Individual Alarm (red), Trouble (yellow) and Power On (green) LED's.
- Initiating Device Circuit: Max. 2,000 m (6,560 ft.) of Protectowire Linear Heat Detector or any number of normally open non-resistive contact devices. Not compatible with 2-wire smoke detectors.

Environmental

- Ambient temperature: 0 - 49°C (32° - 120°F)
- Humidity: Max. 95% non-condensing.

Outputs

- One set of Form C (SPDT) Alarm Contacts and one set of Form C (SPDT) Trouble Contacts rated 1 amp @30 VDC.

Ordering Information

- Model Number: PIM-120
- Description: Single Zone Mini-Interface Module; track mounted.
- Mounting Dimensions: 7.6(w) x 5.0(h) x 2.5(d) cm [3(w) x 2(h) x 1(d) inches]

PIM-120 Commissioning Procedure

Caution: All auxiliary alarm devices and outputs controlled by the Host Fire Alarm Panel should be disconnected prior to connecting the PIM-120 Zone Interface Module to the system.

NOTE: For reference purposes, all instructions are given looking at the component side of the module with the Green LED at the top. Refer to the wiring diagram for detailed terminal designations.

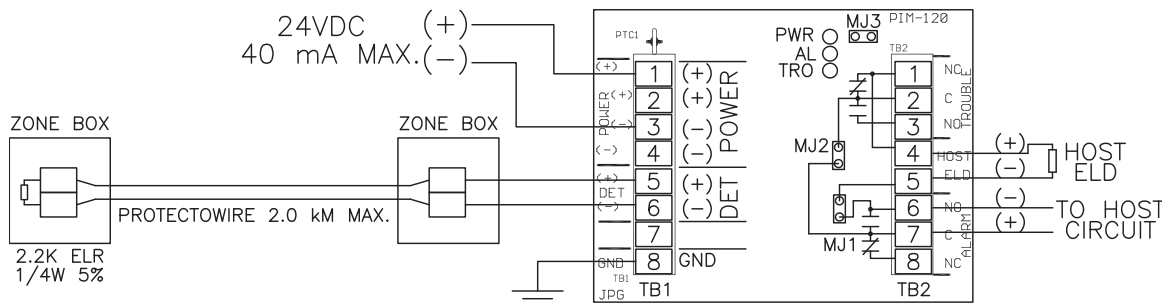

- NOTES:
1. When required connect earth ground to TB1 terminal #8
 2. Remove micro-jumpers MJ1 & MJ2 for independent dry alarm and trouble contacts.
 3. MJ3 installed for latching alarm circuit only.

1. Install a 2.2K ohm 1/4w 5% end-of-line resistor (ELR) across the conductors at the end of the Protectowire run.
2. Measure Protectowire Linear Heat Detector loop resistance prior to connection. Total loop resistance should be between 2.2K and 3.7K ohms. Connect Protectowire Linear Heat Detector across terminals 5 & 6 marked DET (+) and (-) on terminal block TB1.
3. Connect host panel's end-of-line device across terminals 4 & 5 marked HOST ELD on terminal block TB2. See host panel wiring specification, if polarity is required, connect (+) to terminal 4, (-) to terminal 5.
4. Connect host panel's initiating device circuit across terminals 6 & 7 marked ALARM C & NO on TB2. See host panel wiring specification, if polarity is required, connect (+) to terminal 7, (-) to terminal 6. The host panel's initiating device circuit must accept normally open alarm shorting and normally closed trouble opening devices.
5. Connect a regulated 24 VDC switched power source across input terminals 1 & 3 marked POWER (+) & (-) on TB1. Turn on power. Only the green "POWER ON" LED should be on and the host panel initiating device circuit trouble indication should clear. When grounding is required by code or local authority, connect terminal 8 marked GND on TB1 to earth ground.
6. At the end of the Protectowire Linear Heat Detection loop open the circuit at the 2.2K end-of-line resistor. The yellow "TROUBLE" LED on the PIM-120 Interface Module will light and the host panel should report a trouble condition. Reconnect the end-of-line resistor and the "TROUBLE" LED will extinguish and the host panel should reset to normal. Note: Manual trouble reset of the host panel may also be required depending upon the make and model installed.
7. Short the Protectowire Linear Heat Detection circuit across the 2.2K end-of-line resistor. The red "ALARM" LED on the PIM-120 will light and the host panel should report an alarm condition. If PIM-120 is set to non-latch mode (MJ3 is not installed); clear the PIM-120 IDC short and module will restore to normal standby. If MJ3 is installed and the IDC is set to latch mode; clear the short and momentarily interrupt power to the PIM-120 to restore to normal standby. The PIM-120 must be cleared prior to host control panel reset.